

广州尼博星电子科技有限公司
Guangzhou Nyboxing Electronic Technology Co., Ltd

物料编码 Material encoding	116004	型号 Model	CMI EE8.3-5mH (RoHS)
---------------------------	--------	-------------	----------------------

NO1. 物料清单 Bill Of Material

No.	物料名称 Name of material	规格型号 Specifications and models	制造商 Manufacturer	认证号 Certification number
1	BOBBIN	EE8.3	CHANGCHUN PLASTICS CO.,LTD	E59481
2	CORE	EE8.3	HAINING ZHONGXIN ELECTRONIC CO.,LTD.	/
3	WIRE	UEW MW79 155°C	ZHEJIANG HONGBO ELECTRIC WIRE Co., LTD	E221719
4	TAPE	PZ POLYESTER	JINGJIANG JINGYANG INSULATING PRODUCT CO., LTD.	E165111
5	VARNISH	T-4260	WUJIANG TAIHU INSULATION MATERIAL CO., Ltd.	E228349

NO2.骨架尺寸图 Frame size chart

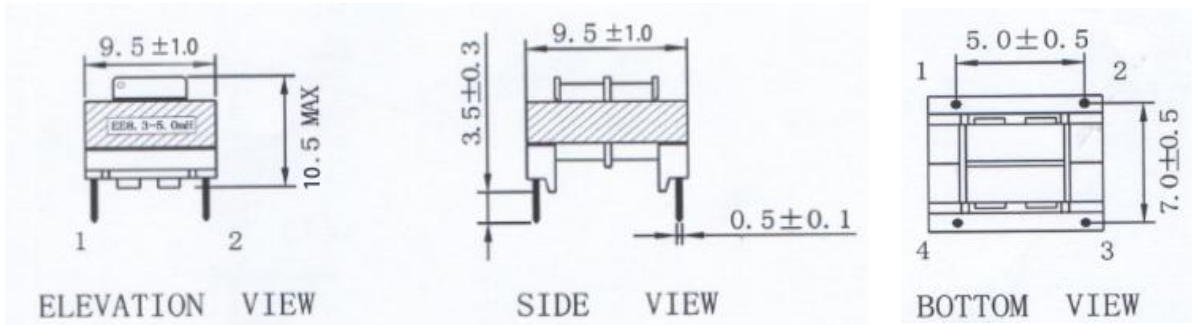

NO3.原理图 Schematic

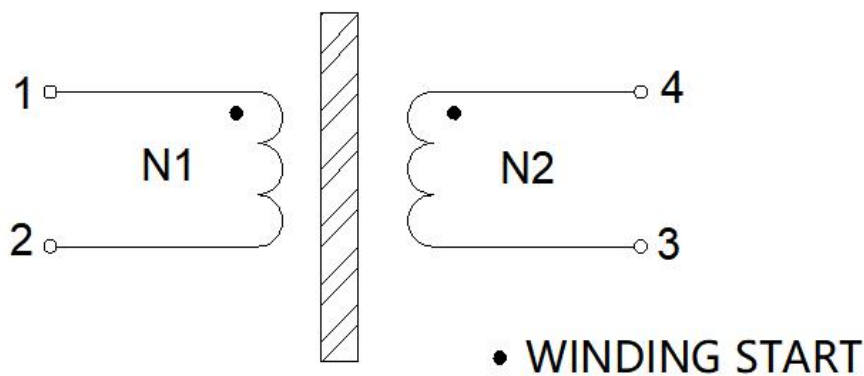

NO3.绕线结构图 Winding structure

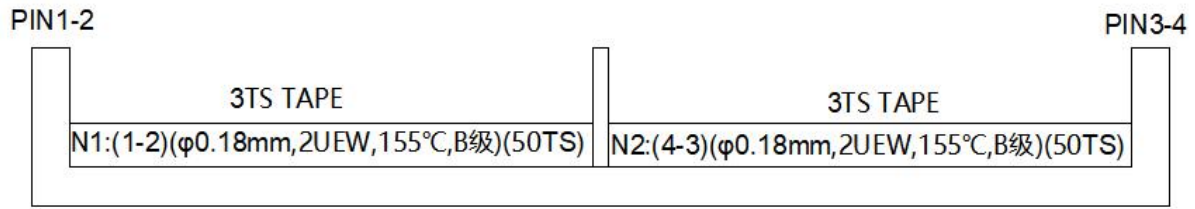

绕组 WDG	进线脚位 BEGINNING	进线套管 TEFLON TUBE	线材规格 WIRESIZE	匝数 TURNS	出线脚位 TERMINAL	出线套管 TEFLON TUBE	绝缘胶纸 层数 TAPE TURNS	备注 Remarks
N1	1脚	/	φ0.18mm , 2UEW , 155°C, B级	50TS	2脚	/	3层	均匀绕
N2	4脚	/	φ0.18mm , 2UEW , 155°C, B级	50TS	3脚	/	3层	均匀绕

NO4.工艺要要求 Process requirements

- ①各绕组的绕制方向均一致;
- ②产品需真空含浸;

NO5.电气性能Electric property

- ①电感量L1 (1-2) ≥5mH; 电感量L2 (4-3)≥5mH; 测试条件@1KHz/0.25V/25°C;
- ②电感偏差|L1-L2|≤0.1mH;
- ③线-线耐压1500VAC/5mA/2s通过;
- ④线-磁芯耐压1000VAC/5mA/2s通过;
- ⑤直流电阻DCR(1-2)≤4Ω; DCR(3-4)≤4Ω; 测试条件@25°C
- ⑥绝缘电阻R≥100MΩ, 测试条件@500VDC
- ⑦工作温度范围: -40°C~125°C