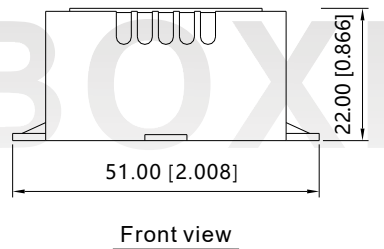
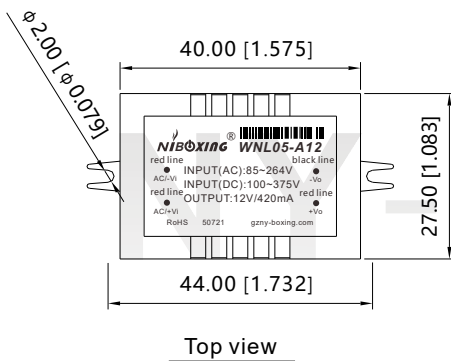

5W AC/DC SMPS
DESCRIPTION

- ★ Wide input AC85~264V & DC100~375V
- ★ Output short circuit, over-current protection
- ★ Compact size, high power density
- ★ I/O isolation test voltage 3k VAC
- ★ Low ripple & noise
- ★ RoHS Compliant
- ★ Industrial grade, high reliability

WNL05-Axx series is one of Nyboxing's highly efficient green power AC-DC Converter series. They feature ultra-wide wide input range accepting either AC or DC voltage, high efficiency, low power consumption and Class II reinforced insulation.

Dimensions

PIN	Function	
	AC IN	DC IN
Red Line	AC	DC
Red Line	AC	DC
Red Line	+Vo	+Vo
Black Line	-Vo	-Vo

Note:
Unit: mm[inch]
General tolerances: $\pm 0.50[\pm 0.020]$

Selection Guide

Part No.	Output Power	Nominal Output Voltage and Current	Efficiency at 230VAC (%) Typ.	Capacitive Load (μ F) Max.	Dimensions (LxWxH)
WNL05-A05		5V/1000mA	68%	1000 μ F	40.0x27.5x22.0mm
WNL05-A09		9V/550mA	70%	680 μ F	
WNL05-A12	5W	12V/420mA	73%	470 μ F	
WNL05-A15		15V/330mA	74%	330 μ F	
WNL05-A24		24V/210mA	76%	220 μ F	

Input Specifications

Item	Operating Conditions	Min	Typ	Max
Input Voltage Range	AC input	85VAC	--	264VAC
	DC input	100VDC	--	375VDC

Input Frequency		47Hz	--	63Hz
Stand-by Power Consumption		--	0.2W	--
Input Current	115VAC	--	120mA	--
	230VAC	--	60mA	--

Output Specifications

Item	Operating Conditions	Min	Typ	Max
Output Voltage Accuracy		--	±3%	--
Line Regulation	Full load	--	±1.5%	--
Load Regulation	10%~100% Load	--	±3%	--
Ripple & Noise*	20MHz bandwidth	5V Output	--	150mV
	(peak-to-peak value)	Other Output	--	100mV
Short Circuit Protection	Hiccup, continuous, self-recovery			
Over-current Protection	≥110%Io			
Minimum Load	0			
Start delay time	500ms			
Hold-up Time	10ms			

Note: * The "parallel cable" method is used for Ripple and noise test, please refer to AC-DC Converter Application Notes for specific information.

General Specifications

Item	Operating Conditions	Min	Typ	Max
Isolation	Input-Output, Test for 1min	--	3000VAC	--
Operating Temperature		-25°C	--	+55°C
Storage Temperature		-40°C	--	+105°C
Storage Humidity		--	--	95%RH
Working frequency		--	65KHz	--
MTBF	MIL-HDBK-217F, 25°C		215,000h	

Product Characteristic Curve

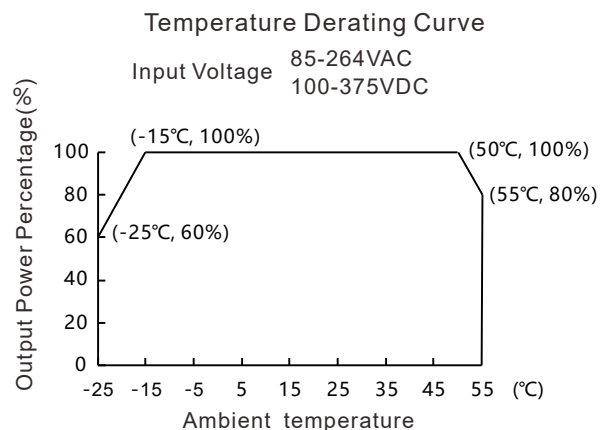
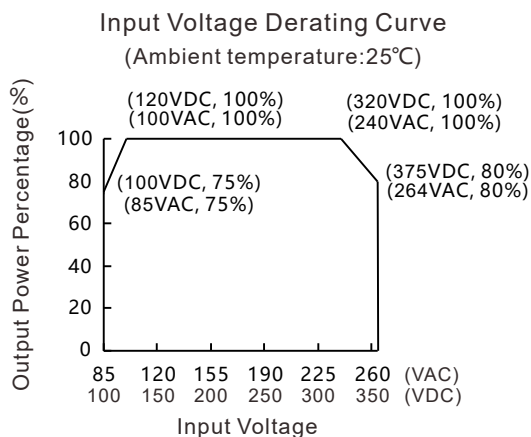

Design Reference

1 Typical application

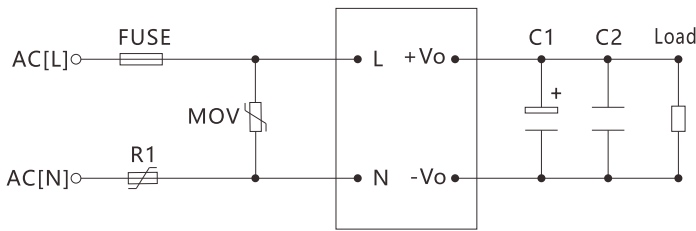

Fig. 1: Typical circuit diagram

Note

We recommend using an electrolytic capacitor with high frequency, and low ESR rating for C1 (refer to manufacturer's datasheet). Choose a Capacitor voltage rating with at least 20% margin, in other words not exceeding 80%. C2 is a ceramic capacitor used for filtering high-frequency noise.

2 EMC compliance recommended circuit

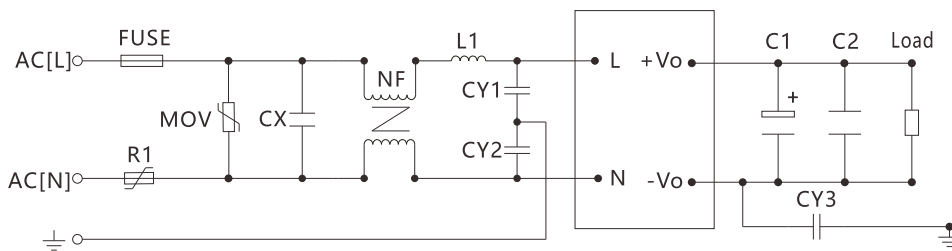

Fig 2: EMC application circuit with higher requirements

3 Input part: parameter recommendation

Component	Recommended value
FUSE	1A/250V slow-blow required
R1	10Ω/1W Safety Resistance
MOV	471KD10
CX	0.1μF/275VAC
L1	470μH
NF	10mH-30mH
CY1,CY2,CY3	1000pF/250V

4 Output part: parameter recommendation

Output Voltage	5V	9V	12V	15V	24V
C1	220μF/10V		220μF/25V		68μF/35V
C2			1μF/50V		

Safety precautions

1. If the product is not operated within the required load range, the product performance cannot be guaranteed to comply with all parameters in the datasheet;
2. Unless otherwise specified, parameters in this datasheet were measured under the conditions of Ta=25°C, humidity<75% with nominal input voltage and rated output load;
3. All index testing methods in this datasheet are based on our Company's corporate standards;
4. We can provide product customization service, please contact our technicians directly for specific information;
5. For more product information, please visit our official website (www.gzny-boxing.com) or email us (sales@gzny-boxing.com).